

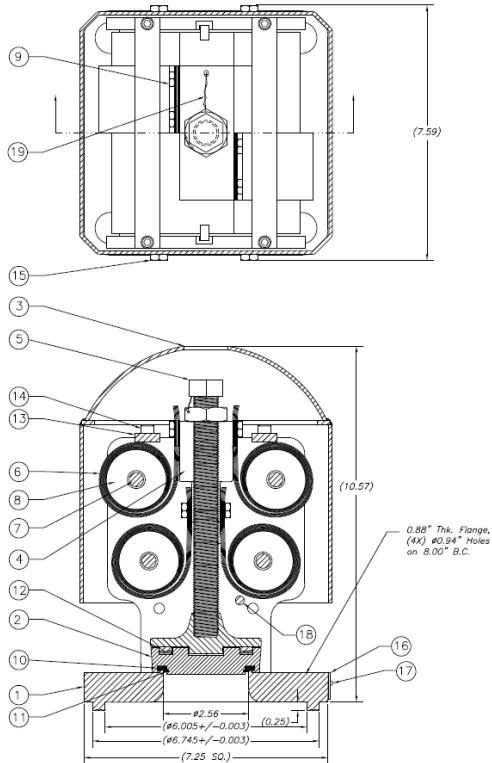

Pressure Relief Valve PC280.5H



Valve Model	PC280.5H
Set Pressure (psig)	280.5
Orifice Diameter (in)	2.56
Flow Area (sq. in)	5.14
Weight (lbs.)	43
Flow Rate @ 308.5 psig	23,396 SCFM
Height (in)	10.82
Flange Thickness (in)	0.875
Number of Bolt Holes	4
Bolt Hole Size (in)	0.94
Bolt Circle (in)	8.00
Interface Options	Tongue & Groove
Number of Springs	53

AAR Approval Number			PC280.5H
PRD172102			
ITEM #	QTY.	DESCRIPTION	MATERIAL
1	1	Body Assembly	Carbon Steel - A516 Grade 70
2	1	Sealing Disc	Stainless Steel
3	1	Cover	Carbon Steel
4	1	Spring Block Assembly	Carbon Steel
5	1	Adjustment Screw Assembly	4140 Alloy Steel
6	8	Spring Drum Assembly	Stainless Steel
7	4	Drum Bolt	Carbon Steel
8	4	Spring Drum	Nylon 6/6
9	16	Spring Bolt	Stainless Steel
10	1	Seal*	Elastomer
11	1	Spirolox Ring	Stainless Steel
12	1	Needle Bearing	Hardened Steel
13	2	Spring Bracket Brace	Carbon Steel
14	4	Brace Bolt	Carbon Steel/Zinc Plated
15	4	Cover Bolt	Carbon Steel/Zinc Plated
16	1	Name Plate	Aluminum
17	2	Nameplate Rivet	Stainless Steel
18	1	Lift Stop	Stainless Steel
19	1	Wire/Seal	Stainless Steel/Lead

*Under Service Trial – ST 468

Patent#: US 9,568,146

Seal material composition based on specification

Other Sealing options available

Note: Mounting flange gasket not supplied

*Alternate Materials Available